

Race Montpellier Seat

Montpellier was originally designed in collaboration with world-renowned architects Foster + Partners, for Cambridge University's Law Faculty. The design addresses the specific needs of the lecture theatre, and provides exceptional postural support and comfortable cushioning for extended periods of sitting.



Additional info and options

- End-of-row lighting
- End-of-row panels
- Foldaway writing tables
- Fixed writing shelves

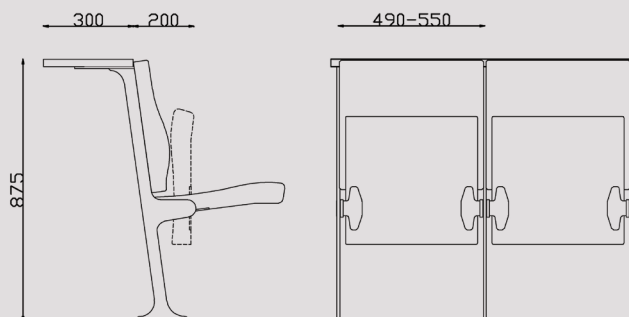

Note: Dimensions are approximate as products are designed to specification